

## **Highway Driving Speed Limiting System with Wi-Fi Module Based on Nodemcu Esp8266**

**M. Al Ali Faizal<sup>1</sup>, M.Rifqi Tsani<sup>1</sup>, Siti Shofiah<sup>1</sup>**

<sup>1</sup> Automotive Engineering Technology, Road Transportation Safety Polytechnic, Tegal

### **Abstract**

High speed while driving is a factor that causes increased fatalities when traffic accidents happen; accidents due to exceeding the speed limit often occur on freeways or toll roads and often cause fatalities. In order to prevent speed limit violations and reduce fatality rates in the event of an accident, in this research, a device that can limit the speed when driving on the toll road is made by relying on Wi-Fi and the NodeMCU ESP8266 microcontroller. The research method used is the Research and Development (RnD) method. The product trial determines the success rate of the designed tool. This study carried out three stages of testing, namely, the initial trial, the first implementation test, and the second implementation test, for implementation test was carried out using a dyno test as a simulation of driving speed on toll roads and using two variables laying. The results of this study, the speed limiter can be implemented on the vehicle and can function to limit the speed of  $\pm 90$  km / h when placed on the APP sensor. The tool can read the sensor voltage signal and send a voltage signal to the ECU according to the programming concept that has been designed.

**Keywords:** *Speed limiting, NodeMCU ESP8266, Wi-Fi, Research and Development, Dyno Test*



This is an open access article under the CC-BY-NC license.

### **INTRODUCTION**

Traffic violations generally precede accidents; driving at high speed alone can cause a high fatality rate for accident victims. Based on some traffic accident data in Indonesia shows that the human factor, in this case, the driver is the main factor that causes accidents (Kusmaryono, 2014). An example of a case still widely discussed is an accident involving an Indonesian artist and his family on the Nganjuk Toll Road towards Surabaya on Thursday (4/11/2021) at 12.36 WIB, which resulted in the artist and her husband's death. Based on the investigation result by the East Java Police Ditlantas Investigation Team, accidents are caused by loss of driver concentration and high vehicle speeds (Cindy, 2021).

One of the driver's mistakes in driving that can lead to accidents is not paying attention to the speed limit, especially when crossing toll roads. This driving behavior can result in a high chance of a single-vehicle crash. The higher the speed of driving, the greater the fatality rate at the time of an accident; therefore, it is necessary to pay attention to the speed limit based on the road that is traversed when driving (Kusmaryono, 2014).

The development of technology creates supporting devices that can make it easier for humans to carry out tasks or work. One example of police officers controlling Overspeed on toll roads has been facilitated by using a tool that can determine the speed of vehicles when passing on the road (speed gun). Speed detection has now progressed by using a CCTV camera, making it easier for the police to do their job. However, such technology can only be used as proof of ticketing that the driver commits a speed violation on a road section, not demanding the possibility that the

violation will be repeated if he feels the road is quiet. Therefore, we need a tool that can perform automatic speed limiting on the vehicle when entering the toll gate. Using a Speed Limiting System for Driving on Toll Roads with a Nodemcu Esp8266 Based Wi-Fi Module is an effective and simple step.

### **LITERATURE REVIEW**

In a study conducted by Harish et al. (2015) to make a maximum speed limiting device on vehicles with a warning system via SMS, the system can work to detect vehicles if the speed exceeds a predetermined limit, which will then provide a warning in the form of SMS. There is a deficiency in this tool, namely the discrepancy in the reading of the motor rotation speed with what is displayed on the LCD or sent to SMS (less accurate). In the research of Fahrian et al. (2018) from the test results, the system can work to send SMS data on speed and use of the gas pedal when the vehicle is traveling more than 60 km/hour and the throttle valve opening is 62% to the vehicle owner and gives a light signal to the driver. However, this system experiences signal problems from the SIM Card if the vehicle is in an area where a signal is unavailable. According to the research results of Jelli Saliandro et al. (2020), this tool detects the speed of vehicles that cross laser sensors installed across the road. The results of the tool testing carried out ten times, the speed value measured manually with the speed value generated by the tool shows a difference in the average value of 3.252 cm/s. The research being conducted now is in the form of implementing a speed limiting system by trying to apply it directly to the vehicle, limiting it directly by controlling the use of the gas pedal through setting the TPS signal voltage, no longer just giving vehicle speed warnings by sending SMS to the owner or giving a light signal to the owner if the driver is driving more than specified and uses the Wi-Fi module to switch the speed limiter system activation and also as a sign that the vehicle is on the toll road.

### **RESEARCH METHOD**

This research is a Research and Development (R&D) that aims to produce speed-limiting devices on toll roads. The Research and Development method is a research model that produces new products or refines previously researched products to create more effective products (Sutabri et al., 2021). According to Sugiyono (2009), there are several stages in the R&D method, which will be described as follows:

#### **A. Needs Analysis**

In this method, the initial stage is carried out, namely analyzing the problems that occur and conducting a literature study to meet the planning needs of the system made by researchers.

#### **B. Design Development**

At this stage, the design of the system to be developed is made, assembling, and then coding the program is entered as a command.

#### **C. Implementation**

This stage is carried out to determine whether there is an error in the system when it is implemented. If there is an error in the system, improvements will be made, but if the system does not, it can be said to be in accordance with the concept of the researcher.

**FINDINGS AND DISCUSSION**

**A. Tool Design**

In designing this tool, an application or software is needed to design a circuit consisting of several components with different functions to then be connected to form an interconnected circuit scheme. In this study, the author uses the Fritzing application to assist in making a circuit schematic of a speed-limiting system for driving on toll roads with a Wi-Fi module based on NodeMCU ESP266.

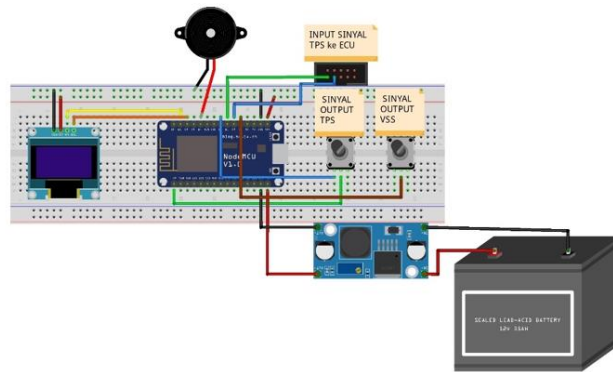

**Figure 1.** Design of a Speed Limiting Tool

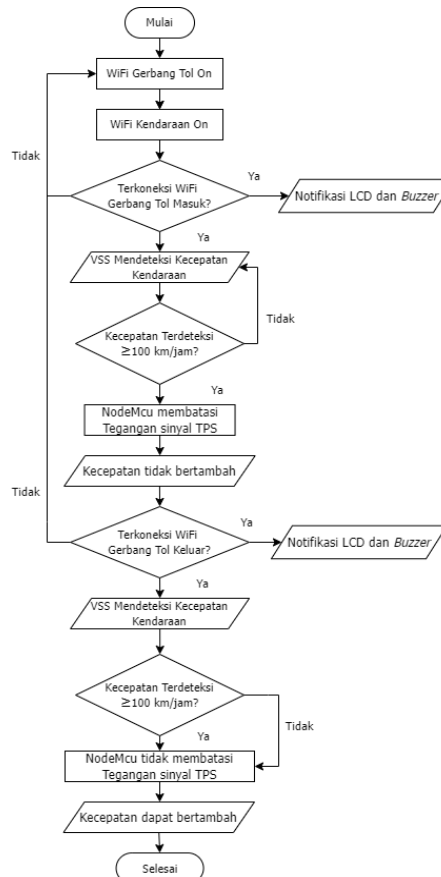

**Figure 2.** How the Tool Works

Based on Figure 1, when the Wi-Fi on the device is connected to Wi-Fi 1, the tool will be on, meaning that the NodeMcu will command the LCD and buzzer, which functions as a receiving component to provide notifications that the device is active by giving the "Tool On" display on the LCD and making the buzzer sound once. Suppose the vehicle speed is detected to be 100 km/h when the device is on. In that case, the NodeMcu will command the TPS, which is also the receiver, to limit the signal voltage sent to the ECU so that no additional RPM can make the vehicle go above 100 km/h. If the Wi-Fi on the device is connected to Wi-Fi 2, the device will turn off, meaning that the NodeMcu will give a command to the LCD, and the buzzer will give a notification in the form of displaying "Tool Off" on the LCD and make the buzzer sound once. The opposite will happen, even if the vehicle speed is detected to be 100 km/hour. However, the device is in the off condition; the NodeMcu will not limit the TPS voltage signal so that there is an increase in RPM, and the vehicle can go above 100 km/hour.

### B. Tool Implementation

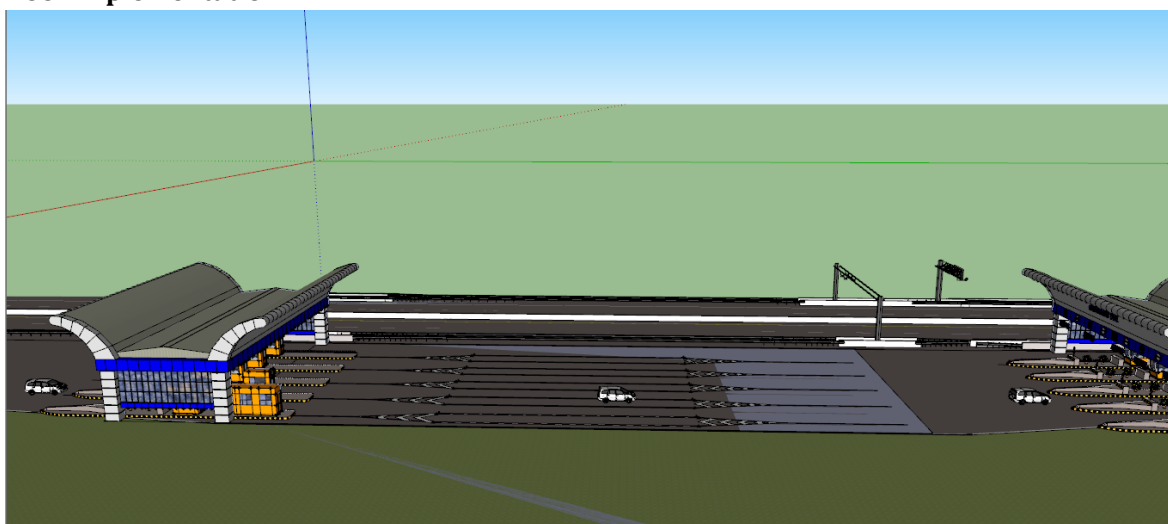

Figure 3. Simulation Scheme of Application on Toll Roads

1. Conditions when the vehicle is about to enter the toll road, the Wi-Fi on the device is preparing to pair with Wi-Fi 1, and the speed limit is not active.
2. When the vehicle has entered the toll road, the device has been connected to Wi-Fi 1. The speed limit will be active when the trigger has been met so that the vehicle will not exceed the predetermined speed limit of  $\pm 90$  km/hour.
3. When the vehicle is about to leave the toll road, the Wi-Fi on the device is preparing for pairing with Wi-Fi 2. The device will not limit the speed even if the trigger for the restriction is met.

### C. Implementation

The first implementation test was carried out by implementing the tool on a practical vehicle at the Road Transport Safety Polytechnic TRO workshop for the Kijang Innova using the Dyno Test to test the tool at a speed of 100 km/h.

1. Prepare the tools and materials for the trial, namely the Kijang Innova practice vehicle and the Dyno Test.



**Figure 4.** Materials and Test Equipment

2. Installing the tool on the vehicle by paying attention to the cable on the APP sensor so that there is no damage to the sensor. The TPS and VSS sensors are replaced in this second stage with APP sensors.



**Figure 5.** Installation of the Tool on the APP Sensor

3. Placing the vehicle that has the tool installed on the Dyno Test, before carrying out the test, make sure a rope firmly ties the back of the vehicle. This is for security and safety when the test is carried out.



**Figure 6.** Putting the Vehicle on the Dyno Test

4. Turn on the vehicle engine and make sure the tool turns on by looking at the OLED on the tool.



**Figure 7.** The vehicle engine and the device are running

5. Activate Wi-Fi 1, which will be used as a sign that the vehicle is at the toll entrance gate, by pairing the Wi-Fi module with a power bank.



**Figure 8.** Preparation to enter the toll gate and connect to Wi-Fi 1 (simulation)

Figure 7 illustrates the condition when the vehicle approaches the toll gate entrance. After the vehicle enters the Wi-Fi 1 coverage area until the vehicle is at the toll gate, as illustrated in Figure 8. Wi-Fi on the vehicle will try to connect to Wi-Fi 1, which takes about 2-5 seconds to connect.

6. Drive the vehicle by stepping on the gas pedal fully in stages in fifth gear, then see on the speedometer whether the speed exceeds 100 km/h. The implementation test of the two-vehicle speeds can be limited to  $\pm 90$  km/hour by the tool, as shown in Figure 9.



**Figure 9.** Car Speed is limited to  $\pm 90$  km/hour

#### 7. Tool Test Results

Figure 10 shows the output voltage results of the tool at the time before the restriction until the speed limit occurs. It can be seen that the output voltage can increase when the speed is  $<90$  km/hour, when the speed is  $>90$  km/hour, the output voltage of the device should also increase, but when the speed limit occurs, the output voltage will remain at the specified voltage, thus keeping the speed constant at 90 km/hour.

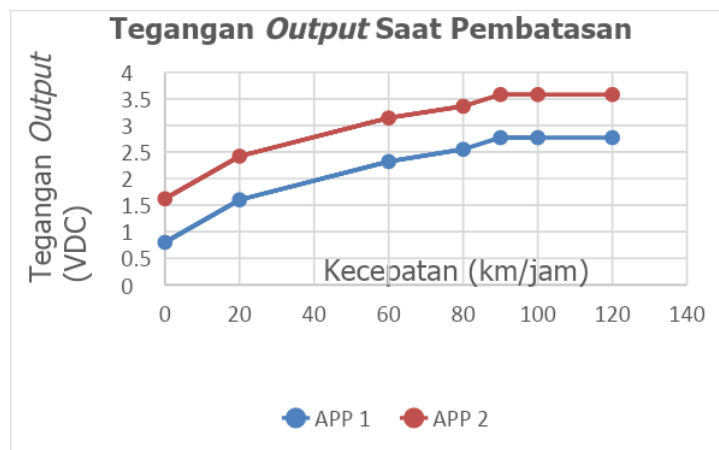

**Figure 10.** Output When Restricted

#### CONCLUSION AND FURTHER RESEARCH

From the results of the research on the Speed Limiting System for Driving on Toll Roads with a Wi-Fi Module Based NodeMCU ESP8266, which was carried out at the TRO Workshop of the Road Transport Safety Polytechnic, the authors can conclude as follows:

- a. Speed Limiting System for Driving on Toll Roads with Wi-Fi Module Based on NodeMCU ESP8266 can be realized as a tool and implemented directly on vehicles, but there are still shortcomings.
- b. The performance of the Speed Limiting System for Driving on Toll Roads with the ESP8266 NodeMCU-Based Wi-Fi Module serves to limit the speed of the vehicle during the implementation test, to be able to do speed restrictions, install the right tool, namely the APP sensor because when the tool is installed on the vehicle, it is not installed. This causes

the check engine to turn on so the device can limit the speed when connected to Wi-Fi 1, and the APP 1 signal voltage limit is met. If it is connected to Wi-Fi 2, the device will not limit the APP 1 signal voltage limit is met. Unlike when installing on TPS, there are still problems with the tool marked by the check engine on the dashboard. However, the APP still has drawbacks; namely, the voltage-current sent by the tool to the ECU is unstable, resulting in unstable engine RPM when stepping on the gas pedal, normal RPM only when idle, and also causing the gas pedal to be unresponsive.

Based on the creation and implementation of the Toll Road Driving Speed Limiting System with the ESP8266 NodeMCU-Based Wi-Fi Module, there are several suggestions that the author will convey, namely:

- a. Product Utilization  
In further research, it can be appropriately applied to all private passenger vehicles, especially vehicles that still lack safety features, such as LCGC and old production vehicles that are not equipped with safety features.
- b. Further development
  1. Adding a circuit to stabilize and amplify the voltage on the device so that the output voltage of the device is more stable.
  2. Make the connecting connector from the tool to the sensor easier when installing and tidier.
  3. For vehicles that already have ABS, you can use the speed sensor on the wheel as a trigger to better match the speed reading.

## REFERENCES

- Cindy. (2021). Officially Become a Suspect, here are 5 Latest Facts. [www.medcom.id/national/law/8N0wQP5K-tubagus-joddy-official-jadi-tersangka-ini-5-fact-terkini](http://www.medcom.id/national/law/8N0wQP5K-tubagus-joddy-official-jadi-tersangka-ini-5-fact-terkini).
- Fahrian, H., Munahar, S., & Putra, D. S. (2018). Development of a Security System Circuit to Improve Driver Behavior Control on Vehicles. *Automotive Experiences*, 1(1), 13-19.
- Harish, M.I. & Hidayat, S. (2015). *Simulation of maximum speed limiting on vehicles using a DC motor RPM with a warning system via SMS (Short Message Service)* [Doctoral dissertation, PLN Technical College].
- Kusmaryono, I. (2014). *Study on Clearance and Speed of Vehicles Moving on Toll Roads (Case Study of Jakarta Outer Ring Road Toll Road)*. 22–24.
- Kaban, J. S. P., Hapsari, G.I., & Sari, M.I. (2020). Design and Build a Car Speed System with Wired Network (Cable) communication. *eProceedings of Applied Science*, 6(1).
- Sutabri, T., Octavianto, T., & Widodo, Y.B. (2021). *Design of Automatic Feeding Equipment for Betta Fish Using Fuzzy Logic, Faculty of Information Technology, Universitas Respati Indonesia in short, the Internet of Things is a technology in which objects around Andriawan (2018) Students from*. 7(2).