

## **Automatic Speed Bump (ASeB) to Reduce the Rate of Traffic Accident**

**Abdul Rokhim<sup>1</sup>, Hanendyo Putro<sup>1</sup>, Dani F. Brilianti<sup>1</sup>**

<sup>1</sup>Polytechnic of Road Transportation Safety, Indonesia

### **Abstract**

The number of road traffic accidents is a complicated problem that has never been separated from the government's attention since the national development began to be implemented, especially in the transportation sector. From the three categories of road, sea, air, and rail traffic, road traffic does have the greatest risk of accident rates compared to others. In this case, it needs the development system, including the manufacture of designing Automatic Speed Bump known as an ASeB prototype that can detect the speed of the vehicles which pass beyond the maximum speed limits. Road users are expected to provide a psychological effect for the road users to reduce their vehicles' speed. This tool can detect vehicle speeds using ultrasonic sensors and directly give an announcement or warning through sound and running text. Subsequently, it runs the automatic speed bump as the vehicle's speed reducer. By using this system, it is expected that road users can reduce the speed of their vehicles when passing on the road, significantly reducing the number of traffic accidents.

**Keywords:** *ASeB, speed, Arduino, safety, traffic accident*

---



This is an open access article under the CC-BY-NC license.

### **INTRODUCTION**

A speed bump, commonly known as a speed limiter, is a part of the road that is elevated in the form of additional asphalt or cement that is installed across the road to indicate slowing down the speed of the vehicle (Surompo, 2015). In order to improve the safety and health of road users, the height is regulated, and when passing through a road that will be equipped with signs prioritizing a speed bump, especially at night, the speed bump is equipped with a road marking with a contrasting white or yellow oblique line as a sign.

In this country, the size of the speed bump has been regulated in the Decree of the Minister of Transportation Number 14 of 2021 concerning Amendments to the Regulation of the Minister of Transportation Number 82 of 2018 concerning Control and Safety Devices for Road Users (Ministry of Transportation, 2021). There it is stated that the material is made of road material, rubber, or other materials that have similar performance with a height of 5 cm to 9 cm with a total width of 35 cm to 39 cm with a slope of 50%, the highest with a combination of yellow or white and black color measuring between 25 cm to 50 cm so that it is visible to motorists who want to pass. Speed bumps will be helpful if placed and designed according to regulations. The determination of road speed limit in residential areas (residential areas) is a maximum of 20 km/hour with the applicable regulations. Speed bumps will be very useful if it is made by following the rules. Speed bumps that are not followed to standard, it is not only damage the vehicle but also endanger the driver. Inadequate dimensions result in excessive shock loads and vehicle shocks.

## **LITERATURE REVIEW**

The objective of this study is to design an Automatic Speed Bump (ASeB) to reduce the speed of vehicles to reduce the number of traffic accidents. In line with the research on Speed Limiting Analysis in Housing Complexes in Pontianak City, Terryanto (2016) said that the highest speed bump at the research location was 13 cm, while the speed bump was 3 cm with various variations of 15% slope with a sinusoidal shape. Driving comfort for the road user is not so comfortable because it ranges from 2-5 km/hour. This shows results that are not ideal and are complicated by the absence of installation of signs and markings. It is stated that the installation of the speed bump is quite ideal and good if it has a height of 12 cm and a slope angle of 15% and is equipped with the installation of signs and signs as a warning to vehicle drivers.

In addition, in his research, Ismael (2013) said that the decrease in vehicle speed was not only influenced by the slope angle of the road hump but also by the geometric characteristics of the road, road hump, and land use around the location. The data obtained by the researchers show that the number of traffic accidents in the Central Java Regional Police area between 2013 and 2020 increased by 17.17%. Therefore, as a community, it is necessary to participate in the implementation of the Decree of the Minister of Transportation Number 14 of 2021 concerning Amendments to the Regulation of the Minister of Transportation Number 82 of 2018 concerning Control and Safety Devices for Road Users.

One of the efforts that the author can do is to make an ASeB to reduce the number of traffic accidents. This tool will work if it detects the vehicle's speed that exceeds the road's maximum speed limit. Suppose there is a vehicle that passes at speed above the maximum limit. In that case, the speed bump will appear automatically on the road surface, so it is expected to trigger the driver to reduce the vehicle's speed.

Previous studies have shown that speed bump has been permanently installed on the road surface. Hence, their effectiveness needs to be reviewed because if the speed bump is installed on a traffic-heavy road or at certain hours, it will cause traffic jams in the area. Using ASeB as a novelty is expected to reduce the number of traffic accidents.

## **RESEARCH METHOD**

### **A. Research Method**

In this research, the ASeB prototype is designed with simple operations and easy operation. It can be used as a motor vehicle speed detection device simulator by using an ultrasonic sensor. This tool serves to reduce the number of traffic accidents on the road due to the vehicles' speed that exceeds the speed limit that has been determined by the Decree of the Minister of Transportation Number 14 of 2021 concerning Amendments to the Regulation of the Minister of Transportation Number 82 of 2018 concerning Control and Safety Devices for Road Users. This tool works if it detects a vehicle passing at speed exceeding the maximum speed limit of 20 km/hour. Suppose the ultrasonic sensor reads a vehicle with speed exceeding 20 km/hour. In that case, the LCD will display the speed number of the vehicle, and the buzzer will give an announcement or notification in the form of sound to the driver in the form of a notification that within a certain distance a speed bump so that the driver is expected to reduce the speed of his vehicle.

## B. Tools and Materials

Tools and materials used in the manufacture of this tool are stated below:

- a) Hardware
  1. Processor Pentium Core-I5 CPU T4500 @3.0 GHz
  2. RAM 4096 MB
  3. Monitor Generic PnP monitor 1366 X 768; 32 bit 60Hz
  4. Arduino Uno R3
  5. Breadboard
  6. Ultrasonic Sensor SR04
  7. LCD (*Liquid Crystal Display*) 16x2 character
  8. Power Supply
  9. Ultrasonic Sensor
- b) Software
  1. 64-bit
  2. IDE Arduino
  3. USB Driver
  4. Team viewer

## C. Research Procedure

This research procedure includes planning diagrams, measurement systems, system design, and testing procedures for Arduino-Based Automatic Speed Bump to Reduce Traffic Accident Rates.

### a) Diagram Planning

The ASeB system consists of 2 design processes: the software and the hardware. There are components as the input component like an ultrasonic sensor as an input for the distance and travel time of passing vehicles which Arduino Uno and output will process used consists of an LCD as a display of vehicle speed calculations and a buzzer as a notification to the driver if the vehicle speed is detected exceeding the maximum speed limit. For more details, the ASeB can be seen in the block diagram below:

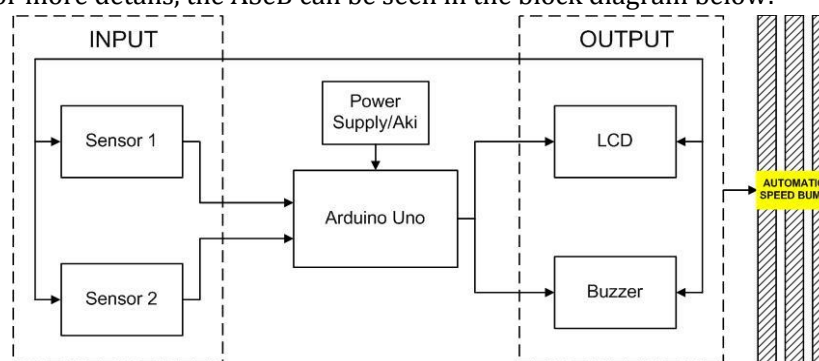

**Figure 1.** The Block Diagram of ASeB

From the block diagram above, the function of each component can be explained as follows:

1. The power supply (Battery) serves to supply power to this system, a power supply so that this system can function properly.
2. Sensor 1 in this warning system functions as an initial timer.

3. Sensor 2 serves to record the second time, which the system will use to calculate vehicle speed.
4. Arduino that has functions as a data processor from the two inputs above, which then the data will be displayed by the LCD.
5. LCD will display information in numbers indicating the speed of passing vehicles.
6. The buzzer in this study serves to notify the driver if the vehicle's speed has exceeded the maximum speed limit specified.
7. Speed Bump provides shock therapy for motorists to reduce the speed of the vehicle so that it is expected to avoid traffic accidents.

#### **b) Measurement System**

Based on the block diagram above, it can be explained that the working principle of the ASeB, where all instructions for running this tool are contained in the Arduino Uno microcontroller as the main controller.

This tool will work shortly after the system is turned on and detect vehicles passing in front of it. The system will read the vehicle's speed after passing through sensor one and sensor two, and the results will be displayed on the LCD in the form of numbers. The calculation of the speed in this system can be seen from the following equation:

$$V = \frac{S}{t_2 - t_1}$$

Where,

V = Speed

S = Distance between sensors 1 and 2

t = Time taken

#### **c) Testing Procedures**

##### **1. Testing Power Supply (Battery)**

The power supply is the voltage and current source of all circuits used in the appliance. The author's tool issued an output voltage of 12V DC and 5V DC in the power supply circuit. The 12V DC voltage is intended for Arduino, which is connected to the jack connector and as a supply voltage for the amplifier as an output. In contrast, the 5V DC voltage is used as the input voltage from the PIR sensor, SR04 sensor, and LCD. The steps that will be carried out in the process of testing the power supply:

- a. Activate the transformer.
- b. Determine the 12V DC output voltage and 5V DC voltage in the power supply.
- c. Measure the output voltage of the power supply using a multimeter.
- d. Observe and record the measured data on the circuit.

##### **2. Ultrasonic Sensor Circuit Testing**

It calculates the reading of the sensor distance data from the object or object in front of the sensor. The display of the distance value from the sensor reading is seen from the serial monitor on the Arduino application when the microcontroller circuit is connected to a PC. To measure the SR04 sensor, the following test steps can be carried out:

- a. Give the supply voltage to Vcc and Gnd of 5V DC
  - b. Connect the trigger and echo pins to the Arduino pin
  - c. Upload the compiled
  - d. Position the ruler in front of the SR04 sensor
  - e. Position an object that can reflecting ultrasonic waves in front of the sensor SR04
  - f. Adjust the distance of the object with the ruler
  - g. Observe the actual distance of the object with that read by the sensor
  - h. Measure the voltage at the trigger and echo using a digital multimeter
- In measuring the distance read by the sensor with the actual distance there is an error, and to determine the percentage. The error can be used this formula:  
(Sensor Reading Distance – Actual Distance x 100) /Sensor Reading Distance

### 3. Arduino Uno Circuit Testing

The next test is carried out on the Arduino Uno microcontroller, which this section is the data processing center for this automatic warning system. The test will be carried out by programming the Arduino microcontroller and measuring the output pin using a multimeter. Steps for testing Arduino Uno:

- a. Make a program using software on Arduino Uno R3, give logic 1 (HIGH) on PIN 1 and on PIN 2 give logic 0 (LOW) like the program below:

```
void setup () {  
  pinMode (1 ,OUTPUT);  
  pinMode(2,OUTPUT);  
}  
void loop () {  
  digitalWrite(1,HIGH);  
  delay(1000);  
  digitalWrite(2,LOW);  
  delay(1000);  
}
```

After the program is finished, download the program into the Arduino Uno microcontroller using a downloader cable.

- b. Calibrate the multi-meter and place the selector on V DC with a scaling limit of 10V DC.
- c. Providing a 5V DC supply to the microcontroller takes measurements at PIN 1 and PIN 2 Arduino

### 4. Buzzer Circuit Testing

Buzzer circuit testing aims to determine the accuracy of the buzzer in making sound, namely the speed of the vehicle detected by the sensor.

- a. Combine Arduino Uno circuit, ultrasonic sensor, and *buzzer*.
- b. Connect the adapter to the circuit.
- c. The movement of objects exceeding the speed of over 20 km / h passes through the ultrasonic sensor, if the buzzer sounds, it means the circuit is running well.

### 5. Speaker Testing

The purpose of this test is to determine whether the circuit can produce commands according to the data obtained by the ultrasonic sensor according to the design.

- a. Connect the speaker circuit (ISD 1820 module to the speaker) to the microcontroller.
- b. Programming the microcontroller to output the desired sound/sound
- c. Connect the adapter to the circuit.
- d. Listening to the sound/sound produced
- e. Record the test results.

#### 6. LCD Circuit Testing

For LCD testing, it is done by entering the program into the Arduino with following steps:

- a) Installing the input cable from the LCD to the Arduino pin,
- b) Making a program using the software on the Arduino Uno.

```
Void loop {  
  Lcd.setCursor(0,0);  
  Lcd.Println("Insha Allah"); }
```

By using that program, on the LCD screen starting from column 0 in row 0, the words "TA Insha Allah" will appear as shown in the image below:



**Figure 2.** LCD test display

## FINDINGS AND DISCUSSION

### 1. Testing of Power Supply

The power supply outputs 4.9V DC and 11.8V DC. Where the voltage of 4.9V DC and 11.8V DC is obtained from the 12V AC voltage, which is rectified by the diode bridge and produces an output voltage of 15.5V DC which then the voltage will be regulated by using the regulator IC 7812 so that the output of this regulator IC becomes 11.8V DC then the voltage. This will be regulated again by using a 7805 regulator IC which regulates the voltage to 4.9 V DC.

The thing that needs to be considered in using this regulator IC is proper IC electric currents. If there is an excess of current, the regulator IC will heat up quickly and can cause the component to be damaged. This 11.8V DC voltage will be used as the input on the amplifier and as the input for Arduino at the jack connector, and the 4.9V DC voltage will be used as the input from the PIR sensor and the ISD1820 module.

**Table 1.** Measurement Results *Power Supply*

No.	Measuring Point	Rated Voltage
1.	TP1	12.2 V AC
2.	TP2	15.5 V DC
3.	TP3	11.8 V DC
4.	TP4	4.9 V DC

## 2. Arduino Uno R3 Circuit

Based on Table 2, the Arduino used in this system is functioning properly. Due to pin 4 on Arduino can be worth 1 and 0.

**Table 2.** Arduino Uno R3 Circuit Test Results

Time (seconds)	Avometer Output (PIN 4)
1	1
2	0
3	1
4	0
5	1

## 3. Ultrasonic Sensor Circuit SR04

The ultrasonic sensor is the primary input of the system because the distance reading data will be processed to be compared with the minimum and maximum water level data. Error reading proximity sensor data will have an impact on decision-making errors later.

**Table 3.** SR04 Ultrasonic Sensor Data Reading Results

No.	Actual Distance (cm)	Sensor Distance (cm)	Error (%)
1.	1	3	66
2.	2	4	50
3.	3	3	0
4.	5	5	0
5.	6	6	0

The ultrasonic sensor works by emitting ultrasonic with a particular frequency and a certain duration; then, this signal propagates as a sound wave with a speed of about 340 m/s and is reflected by the object in front and is captured by the receiver. This is because the ultrasonic can only read the closest distance of 3 cm. For reading distances from 3 cm to 50 cm, there is no error, or it can be said error of 0%. However, for a range distance of 60 cm to 550 cm, there is an error in the reading with an error from 0.54% to 17.6%; this can be caused by the distance of the object being distance and noise signal ultrasonic where noise is a wave interference from outside. When measuring a distance of 600 cm, the reading on the sensor is 3448 cm, which is the largest percentage error, 82.5%. Based on this measurement, it can be stated that the ultrasonic sensor cannot read distances of more than 600 cm. This is in accordance with the SR04 sensor datasheet, which can only read distances from 3 to 500 cm, while measurements read by the sensor of more than 500 cm are unstable distance readings.

## 4. LCD Circuit

The picture below shows the condition of a violation of the maximum speed limit of objects (vehicles) that pass through the ultrasonic sensor. The aim is to warn the vehicle who pass on the highway because they have exceeded the maximum speed limit of 20 km/hour, so it is expected to reduce the speed of their vehicles.



**Figure 3.** LCD Testing

### 5. Design of ASeB

In the design of this tool, speed bumps will automatically appear on the road surface when they know there is a traffic violation, i.e., there are vehicles that pass more than a maximum speed of 20 km/hour past two ultrasonic sensors which are installed a few meters from the point where the speed bumps appear. Before the speed bumps appear on the road surface, the vehicle will be given an announcement or notification from a digital screen installed on the road that the vehicle speed exceeds the maximum limit so that the driver must reduce the vehicle's speed.



**Figure 4.** The Design of the *Prototype*

### CONCLUSION

Based on the results of the analysis and discussion carried out in the previous chapter, the following conclusions can be drawn:

1. This tool can help provide education or appeal to road users or vehicles who still act recklessly on the environmental road, which are classified as relatively dense transportation routes with a maximum speed limit of 20 km/h.
2. Speed bumps will work automatically if they detect the speed of a vehicle that exceeds the maximum speed limit by giving an announcement or notification in advance so that the vehicle driver immediately reduces the speed limit of his vehicle.

### REFERENCES

- Compton, A. H. (2010). *Original Traffic control sketch made by Compton in 1953*. Washington University Libraries.
- Cotton, A. & Wilkinson, G. (1989). *Basic Inorganic Chemistry*. Translator: Suhati Suharto. Assistant: Yanti RA Koestoer. First Printing. Jakarta. Publisher University of Indonesia (UI-Press). Pages: 61;628- 630
- Hobbs, F. D. (1995). *Traffic Planning and Engineering*. Gadjah Mada University Press Publisher



- Ilham, E. (2016). *Understanding and Advantages of Arduino*. <http://www.itjurnal.com/2014/05/pengertian-dan-kelahan-arduino>.
- Ishmael, N. (2013). Analysis of Road-Hump Design in Reducing Vehicle Speed. *Potency*, 15(September 2), 58-68
- Mandarani, P. & Ariani, R. (2016). Design of Cigarette Smoke Detection System Using Short Message Service (SMS) Alerts Based on Arduino. *Jurnal TEKNOIF*, 4(2). <https://doi.org/10.21063/jtif.2016.V4.2.66-75>
- Marshall, E.J.R. (1993). Guidelines for the Design and Application of Speed Humps. *ITE JOURNAL*
- Ministry of National Education (2002). *Big Indonesian Dictionary*. Jakarta: Balai Pustaka
- Ministry of Transportation. (2021). *Decree of the Minister of Transportation Number 14 of 2021 concerning Amendments to Regulation of the Minister of Transportation Number 82 of 2018 concerning Control and Security Devices for Road Users*. Ministry of Transportation, Jakarta
- Morlok, E.K. (1998). *Introduction to Engineering and Transportation Planning*. Erlangga Publisher: Jakarta
- Sukirman, S. (1994). *Fundamentals of Highway Geometric Planning*. Nova: Bandung
- Surompo, B. A. (2015). *Pengaruh Alat Pengendali Kecepatan Vertikal, Lebar Jalan dan Jarak Pemasangan Terhadap Kecepatan*. Matriks Teknik Sipil. UNS: Surakarta.
- Terryanto. (2016). Thesis: Study of Speed Limiting Facilities in a Housing Complex in Pontianak City.
- Winarto, K.M. & Hudaya, B. (1981). *General Physics*. Bandung: Armico